



*We're Holding
Things Together!*

63/64-FC

Riveting Machines

Features

High Production

- Sets two rivets simultaneously.
- Less operator fatigue: solenoid operation of clutch trip mechanism permits placement of operating switch in the most comfortable / convenient position.
- Faster machine cycles with high speed roller clutch.
- Quick, positive delivery of rivet with every machine cycle assured by cut-off type escapement.
- Parts supply bins and spill trays can be placed inches from the setting tools.

Greater Flexibility

- Electrical cycling facilitates installation of many options.
- Quick retooling for different rivet sizes with QC Raceways.
- Raceway interchangeable with Models 255 and 256.

Less Downtime

- Clutch maintenance practically eliminated with roller clutch.
- Clutch trip adjustment never required.
- No hopper drive lubrication - totally enclosed cam clutch.

Longer Life

- Power train toggle linkage made of hardened steel components.
- Slide rails of raceways spring steel; back rail stainless steel.
- Better lubrication through more grease fittings.

Improved Safety

- Machine won't double trip, clutch trip operates by gravity.
- Full power train guarding without loss of production speed.
- Reduced noise level.

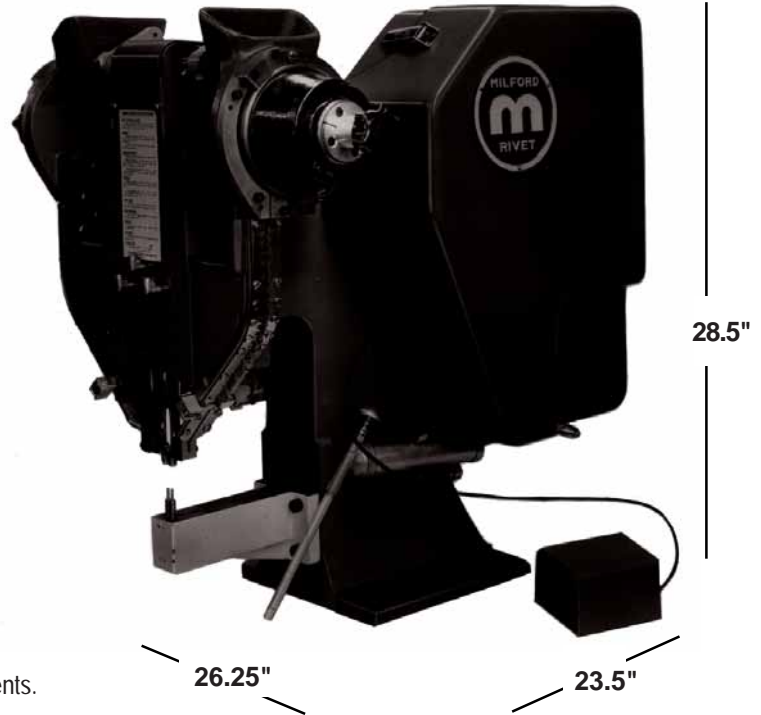

Specifications

Rivet Capacity	63:	1/32 inch (.79mm) to 3/32 inch (2.38mm) diameter, max. length 3/4 inch (19.05mm)	Hopper	Rotary, intermittent drive
	64:	3/32 inch (2.38mm) to 1/8 inch (3.17mm) diameter, max. length 3/4 inch (19.05mm)	Setting Mech.	Toggle, crank driven
Max. Center Spacing	3/4 inch (19.05mm)		Crankshaft	Ductile iron, sleeve bearing mount
Throat Depth	6.25 inches (158.75mm)		Clutch	Roller type, single revolution
Stroke	2 inches (50.8mm)		Clutch Trip	Solenoid trip w/foot switch or palm buttons
Anvil Height	6 inches (152.4mm) from bench top		Flywheel	225 rpm, tapered roller bearing mounted
			Motor	1/6 hp, 1140 rpm, single phase, 60 Hz, 115V (motor options available)
			Weight	250 lbs., approx. 285 lbs. w/crate

www.milfordrivet.com • ph: 517-787-9447 • fax: 517-787-6609 • sales@milfordrivet.com

Forming, Fastening and Assembly Specialists

Double Riveters: Save Time and Money

Multiple rivets close together can prevent parts from turning or shifting. A double riveter reduces the cost of rivet setting in these applications to nearly half. Uses include: production of electronic equipment, hardware parts, toys, cooking utensils and appliances.

Fixed center riveters are used in long production runs or where standardized rivet spacing is designed for multiple products.

Milford Double Spindle Riveters with Fixed Centers

Bench Model 63-FC

Compact model is 23-3/4 inches wide by 23-1/2 inches deep. Sets two rivets up to 0.099 inch maximum diameter and 5/8 inch maximum length on fixed centers up to 3/4 inch.



Floor Model 255-FC

Floor version of Model 63-FC. Throat depth 12 inches, double that of Model 63-FC, and stroke is increased to 2-1/2 inch. This provides extra room for mounting fixtures and loading.

Floor Model 305-FC

Heavy duty riveter designed for rivets up to 9/64 inch diameter and 3/4 inch length on close centers (1-1/2 inch max.). 3-1/2 inch stroke with a 12 inch throat provides the most loading room available with a fixed center double spindle riveter.

Bench Model 64-FC

Similar to Model 63-FC with larger hopper capacity. Designed for rivets up to 1/8 inch diameter and 3/4 inch length.

Many Applications, Many Advantages



This electrical application required two rivets be set simultaneously to ensure correct part orientation. Since the double riveter sets both rivets in the exact same cycle time, production and cost figures are almost identical to those of a single riveter.

REPLACEMENT TOOLING & REBUILDS *for all makes and models of machines*

Milford has over 70 years experience producing tooling for rivet setting machines. We supply highest quality exact replacement tooling. Send us a print or damaged tool - we'll get right back with a quote and delivery information.

Ask about our stock / blanket order programs to assure even faster response to your immediate needs.

Drivers - precision machined, shaped and polished to exact characteristics of rivet or fastener.

Jaws - also called "pockets" capture and position rivet prior to assembly. Designed to match rivet size and length.

Roll Sets - also called "anvils" roll or form the rivet clinch. Controlled clinching through tool shape, finish and surface lubricity is the key to tighter, more dependable and attractive fastenings.



Titan-Tip Roll Sets

Titanium Nitride coating provides a harder, low-friction surface - reducing the coefficient between forming surfaces to one third that of uncoated tools. This ensures there is no tool deformation or base material characteristic change. Titan-Tip coating also increases tool face hardness to a Rockwell C₈₀.

Milford Titan-Tip tools are fabricated for any make or model riveting machine. For better and smoother working clinching tools Titan-Tip is the solution!

Rebuilds

Milford can rebuild your riveting machines to "like new" condition. Rebuilding can be done at a cost significantly lower than a new machine, with quick turnaround. A factory rebuild of any Milford carries the same warranty as a new machine.

Rebuilding your equipment increases productivity and production flow, it also helps eliminate downtime due to machine failure caused by wear.

Operator Safety

Milford recommends all riveters be equipped with safety devices such as dual non-tie-down palm switches or safety ring guards. Call us for our brochure, "Safety in Riveting".



Orbitform Group

1600 Exec.Dr., Jackson, MI 49203
Ph: 517-787-9447 • Fax: 517-787-6609
www.milfordrivet.com • sales@milfordrivet.com