



We're Holding Things Together!

423 Riveting Machine

Features

High Production

- Less operator fatigue: solenoid operation of clutch trip mechanism permits placement of operating switch in the most comfortable / convenient position.
- Faster machine cycles with high speed roller clutch.
- Quick, positive delivery of rivet with every machine cycle assured by cut-off type escapement.
- Parts supply bins and spill trays can be placed inches from the setting tools.

Greater Flexibility

- Electrical cycling facilitates installation of many options.
- Quick retooling for different rivet sizes with QC Raceways.
- Raceway interchangeable with 400 Series Models.

Less Downtime

- Clutch maintenance practically eliminated with roller clutch.
- Clutch trip adjustment never required.
- No hopper drive lubrication - totally enclosed cam clutch.

Longer Life

- Power train toggle linkage made of hardened steel components.
- Slide rails of raceways spring steel; back rail stainless steel.
- Better lubrication through more grease fittings.

Improved Safety

- Machine won't double trip, clutch trip operates by gravity.
- Full power train guarding without loss of production speed.
- Reduced noise level.

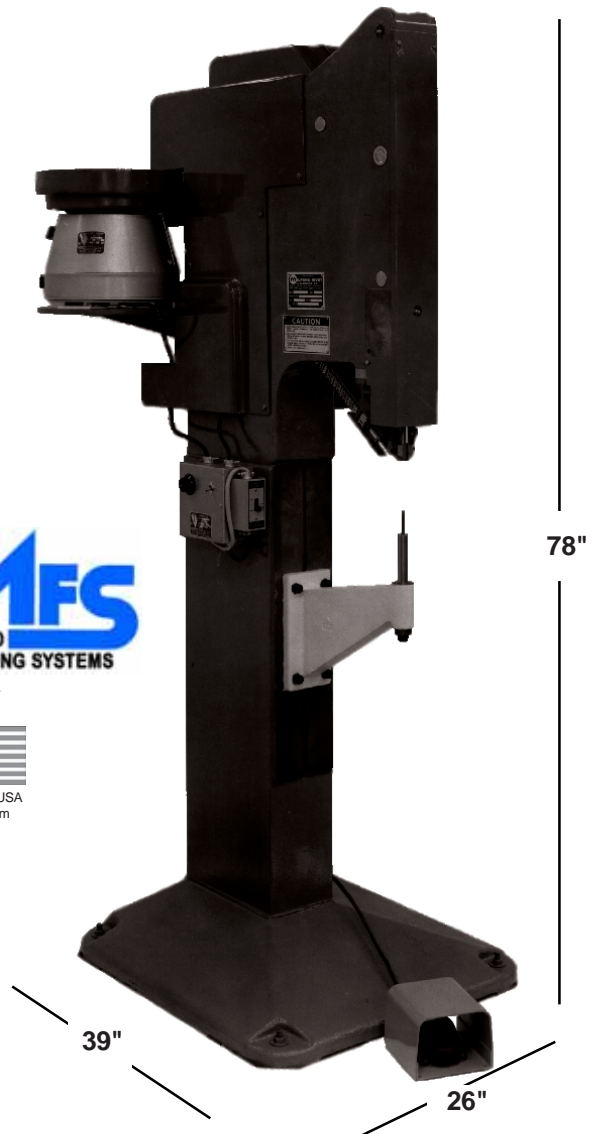

Specifications

Rivet Capacity	Up to 1/4 inch (6.35mm) diameter, max. length 2-3/8 inch (60.32mm)	Setting Mech.	Toggle, crank driven
Throat Depth	12 inches (304.8mm)	Crankshaft	Ductile iron, sleeve bearing mounted
Stroke	5-1/2 inches (139.7mm)	Clutch	Roller type, single revolution
Anvil Height	39 inches (990.6mm) (average)	Clutch Trip	Solenoid trip w/foot switch or palm buttons
Hopper	Vibratory, 14 Inch (355.6mm) diameter	Flywheel	152 rpm, tapered roller bearing mounted
		Motor	1/3 hp, 1140 rpm, single phase, 60 Hz, 115V (motor options available)
		Weight	900 lbs., approx. 1030 lbs. w/crate

www.milfordrivet.com • ph: 517-787-9447 • fax: 517-787-6609 • sales@milfordrivet.com

Forming, Fastening and Assembly Specialists

Titan-Tip Roll Sets

Titanium Nitride coating provides a harder, low-friction surface - reducing the coefficient between forming surfaces to one third that of uncoated tools. This ensures there is no tool deformation or base material characteristic change. Titan-Tip coating also increases tool face hardness to a Rockwell C₈₀.

Milford Titan-Tip tools are fabricated for any make or model riveting machine. For better and smoother working clinching tools Titan-Tip is the solution!

Rebuilds

Milford can rebuild your riveting machines to "like new" condition. Rebuilding can be done at a cost significantly lower than a new machine, with quick turnaround. A factory rebuild of any Milford carries the same warranty as a new machine.

Rebuilding your equipment increases productivity and production flow, it also helps eliminate downtime due to machine failure caused by wear.

Operator Safety

Milford recommends all riveters be equipped with safety devices such as dual non-tie-down palm switches or safety ring guards. Call us for our brochure, "Safety in Riveting".

REPLACEMENT TOOLING & REBUILDS *for all makes and models of machines*

Milford has over 70 years experience producing tooling for rivet setting machines. We supply highest quality exact replacement tooling. Send us a print or damaged tool - we'll get right back with a quote and delivery information.

Ask about our stock / blanket order programs to assure even faster response to your immediate needs.

Drivers - precision machined, shaped and polished to exact characteristics of rivet or fastener.

Jaws - also called "pockets" capture and position rivet prior to assembly. Designed to match rivet size and length.

Roll Sets - also called "anvils" roll or form the rivet clinch. Controlled clinching through tool shape, finish and surface lubricity is the key to tighter, more dependable and attractive fastenings.



Orbitform Group

1600 Exec.Dr., Jackson, MI 49203
Ph: 517-787-9447 • Fax: 517-787-6609
www.milfordrivet.com • sales@milfordrivet.com