



We're Holding Things Together!

106

Contact Setter

For smaller contact assemblies when rivet must be tenon up

Features

High Production

- Faster machine cycles from compact air cylinder operating through toggle type drive linkage.
- Less breakage of assemblies with fragile components by load deflection system.
- Quick, positive delivery of rivet with every machine cycle assured by cut-off type escapement.
- Parts supply bins and spill trays can be placed inches from the setting tools.

Greater Flexibility

- Quick retooling for different rivet sizes with installation of appropriate rails.
- Larger loading area

Longer Life

- Toggle linkage made of hardened steel components.
- Slide rails of raceways spring steel; back rail stainless steel
- Better lubrication through more grease fittings.

Improved Safety

- Solenoid trip permits convenient use of non-tie-down, double palm switches or other safety devices.
- Linkages and most moving parts fully guarded - without loss of production speed.
- Adjustable stroke.

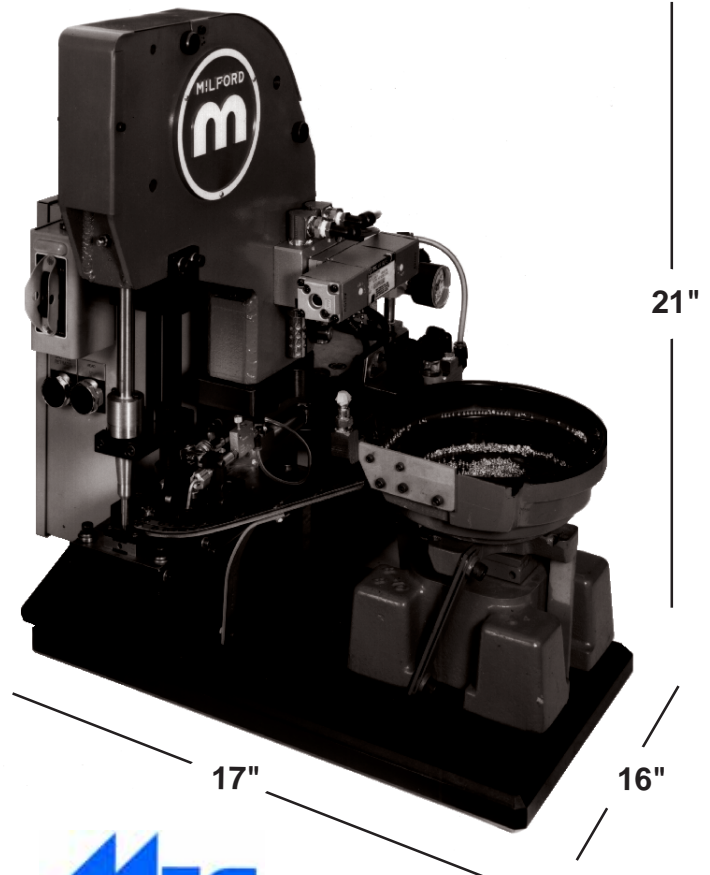

Specifications

Rivet Capacity	3/64 inch (1.19mm) to 3/32 inch (2.38mm) diameter by 3/8 inch (9.52mm) max. length
Stroke	1-1/4 inch (39.68mm)
Hopper	8 inch (203.2mm) vibratory bowl with shuttle feed
Setting Mech.	Toggle, air cylinder driven

Air cylinder	7.6 cubic inches per stroke, per head at operating pressure of 60 to 125 psi
Air valve	Electrically piloted, air operated, remotely mounted, 8 to 12 volts
Weight	Approx. 125 lbs.

www.milfordrivet.com • ph: 517-787-9447 • fax: 517-787-6609 • sales@milfordrivet.com

Forming, Fastening and Assembly Specialists

Titan-Tip Roll Sets

Titanium Nitride coating provides a harder, low-friction surface - reducing the coefficient between forming surfaces to one third that of uncoated tools. This ensures there is no tool deformation or base material characteristic change. Titan-Tip coating also increases tool face hardness to a Rockwell C₈₀.

Milford Titan-Tip tools are fabricated for any make or model riveting machine. For better and smoother working clinching tools Titan-Tip is the solution!

Rebuilds

Milford can rebuild your riveting machines to "like new" condition. Rebuilding can be done at a cost significantly lower than a new machine, with quick turnaround. A factory rebuild of any Milford carries the same warranty as a new machine.

Rebuilding your equipment increases productivity and production flow, it also helps eliminate downtime due to machine failure caused by wear.

Operator Safety

Milford recommends all riveters be equipped with safety devices such as dual non-tie-down palm switches or safety ring guards. Call us for our brochure, "Safety in Riveting".

REPLACEMENT TOOLING & REBUILDS *for all makes and models of machines*

Milford has over 70 years experience producing tooling for rivet setting machines. We supply highest quality exact replacement tooling. Send us a print or damaged tool - we'll get right back with a quote and delivery information.

Ask about our stock / blanket order programs to assure even faster response to your immediate needs.

Drivers - precision machined, shaped and polished to exact characteristics of rivet or fastener.

Jaws - also called "pockets" capture and position rivet prior to assembly. Designed to match rivet size and length.

Roll Sets - also called "anvils" roll or form the rivet clinch. Controlled clinching through tool shape, finish and surface lubricity is the key to tighter, more dependable and attractive fastenings.



Orbitform Group

1600 Exec.Dr., Jackson, MI 49203
Ph: 517-787-9447 • Fax: 517-787-6609
www.milfordrivet.com • sales@milfordrivet.com